



New

Superior Clamping and Gripping



## The new SCHUNK Grippers PGN-plus-P and PGN-plus-E

Now NEW with permanent lubrication  
in the multi-tooth guidance!



## Superior Clamping and Gripping

Jens Lehmann stands for safe, precise gripping and holding. As a brand ambassador of the SCHUNK team, the No. 1 goalkeeper represents our global competence leadership for gripping systems and clamping technology. The top performance of SCHUNK and Jens Lehmann are characterized by dynamics, precision, and reliability.

For more information visit our website:  
[schunk.com/lehmann](http://schunk.com/lehmann)

*J. Lehmann*  
Jens Lehmann





Henrik A. Schunk, Kristina I. Schunk, brand ambassador Jens Lehmann, and Heinz-Dieter Schunk

## Top Performance in the Team

SCHUNK is the world's No. 1 for gripping systems and clamping technology – from the smallest parallel gripper to the largest chuck jaw program.

In order to boost efficiency, SCHUNK customers have bought more than 2,000,000 precision toolholders, 1,000,000 SCHUNK grippers, and 100,000 lathe chucks and stationary workholding systems so far.

This makes us proud and motivates us to attain new top performances.

As a competence leader, we recognize and develop standards with a large potential for the future, which will drive the rapid progress in many industries.

Our customers profit from the expert knowledge, the experience, and the team spirit of more than 2,800 employees in our innovative family-owned company.

The Schunk family wishes you improved end results with our quality products.



Heinz-Dieter Schunk



Henrik A. Schunk



Kristina I. Schunk

## Superior Clamping and Gripping

# It's time to use your machine's

With superior components, find potentials in your machine, where you would least expect to find them.

**Make full use of your machine's potential – with the extensive product portfolio from SCHUNK.**

SCHUNK, the competence leader for gripping systems and clamping technology, can now open up the full potential of your processing machines and production processes. Reduce costs by combining accurate, flexible workpiece machining with dynamic production automation.

**SCHUNK Synergy – when everything fits together.**

With SCHUNK Synergy, you benefit from superior components from our innovative family-owned company and the result of a perfectly harmonized interplay of clamping technology and gripping systems. The more SCHUNK, the more efficient it is.

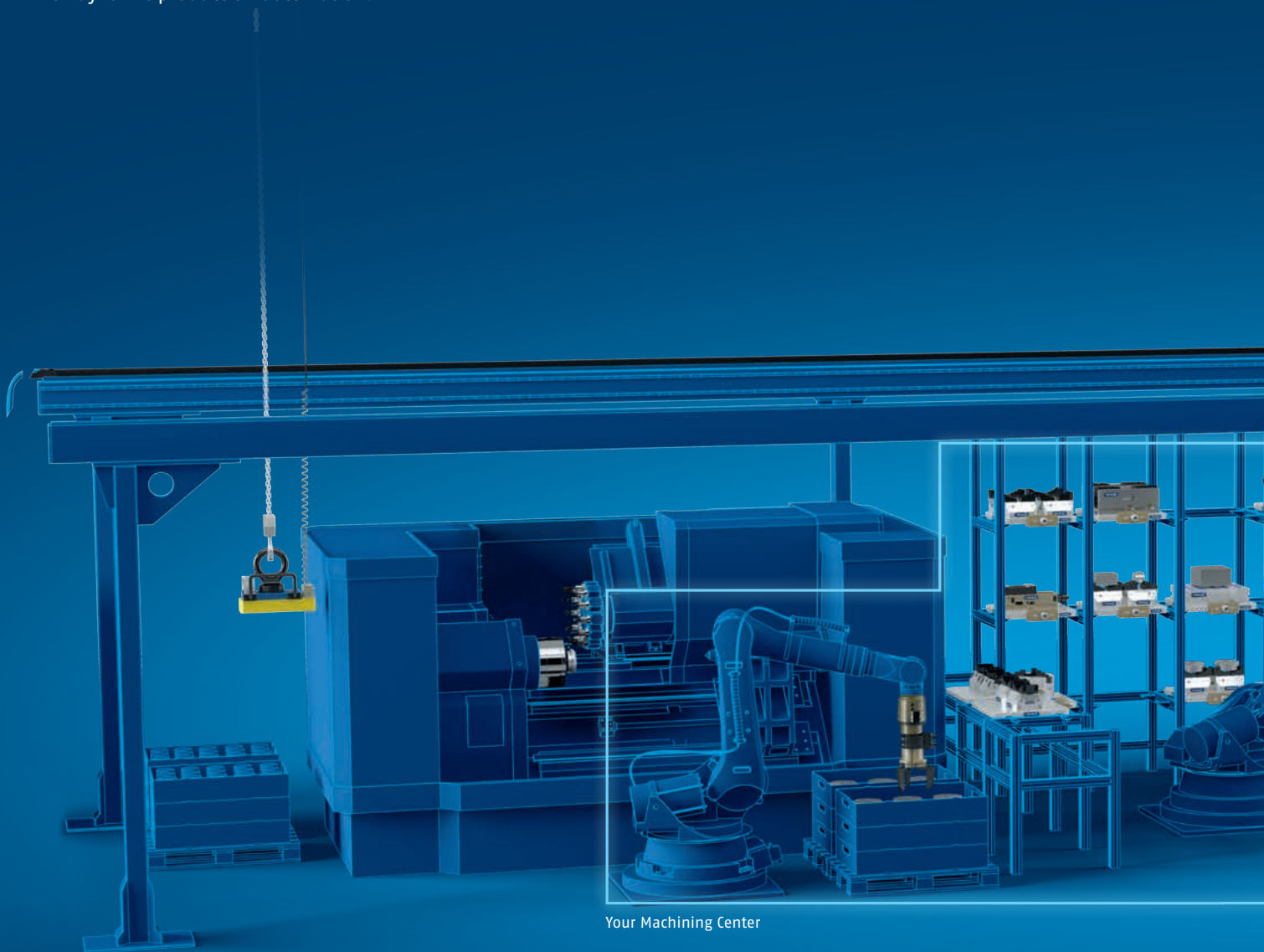

Your Machining Center

# full potential!



## SCHUNK Gripper Modules

Precise grip!  
From a few grams to over a ton.



## Linear Modules

Moves precisely!  
High speed in all axes.



## Modular Assembly Automation

Uniquely individual!  
Due to the flexibility of the modular system.



## Robot Accessories

Perfectly connected!  
The interaction between robot and tool.



## Rotary Modules

They master it!  
Limited or endless – free or clocked.



## Mobile Gripping Systems

Technologies for handling the future.

Your Automated Handling System

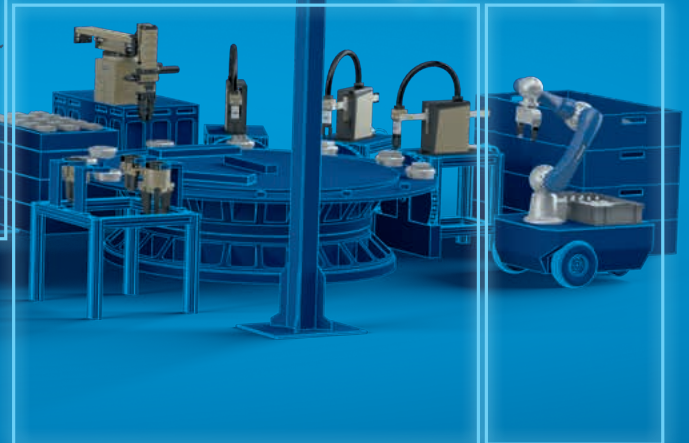
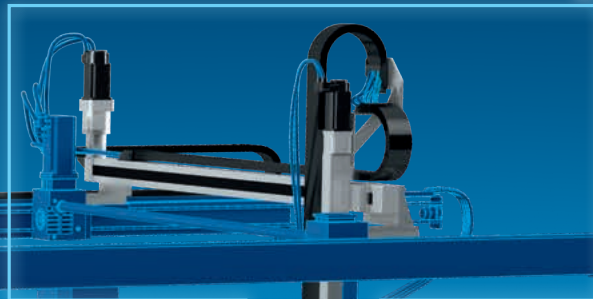

Your Automated Assembly

Your Service Robotics Application



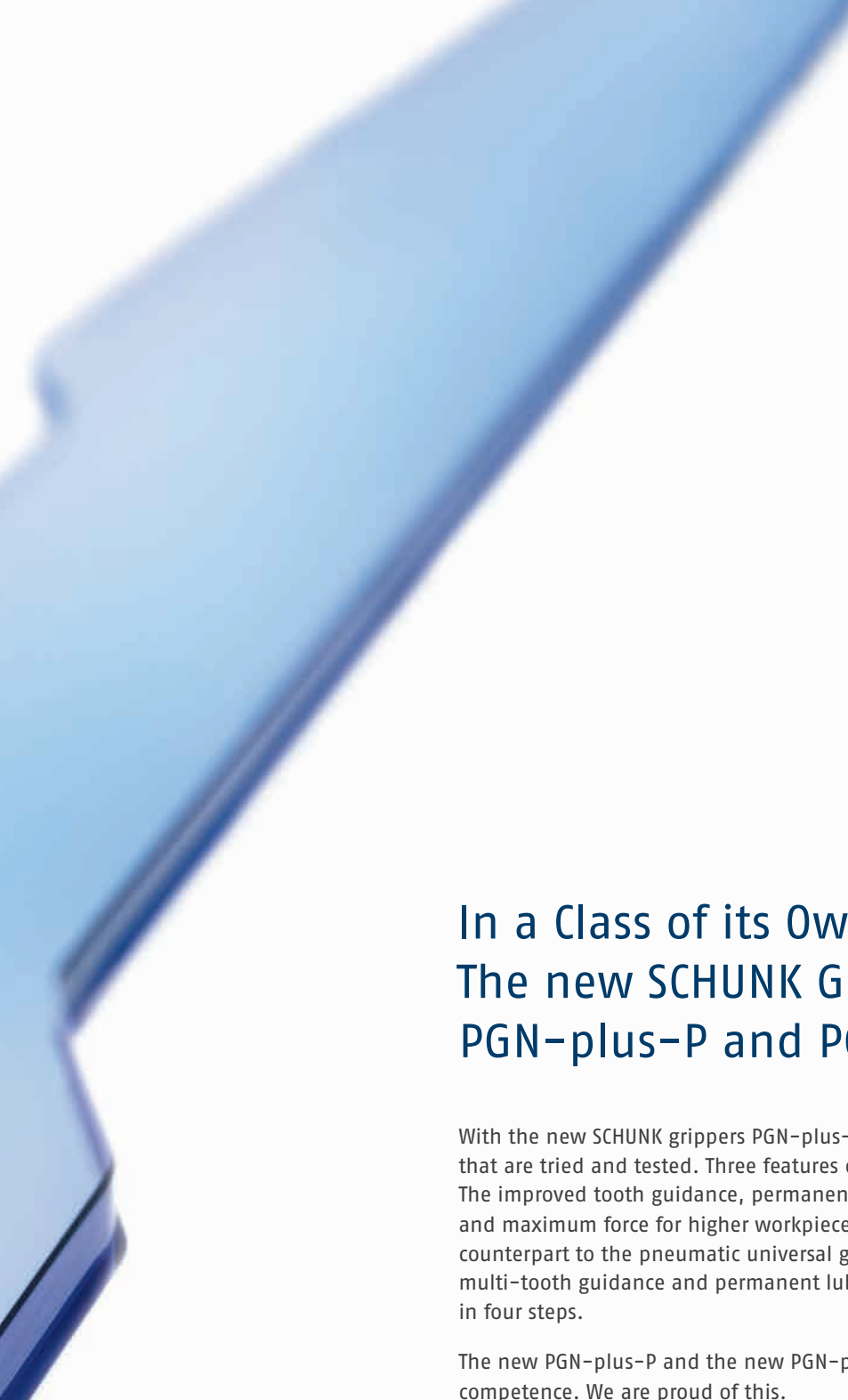

## In a Class of its Own. The new SCHUNK Grippers PGN-plus-P and PGN-plus-E.

With the new SCHUNK grippers PGN-plus-P and PGN-plus-E, SCHUNK improves things that are tried and tested. Three features characterize the pneumatic new PGN-plus-P: The improved tooth guidance, permanent lubrication with continuous lubricant pockets and maximum force for higher workpiece weights. The new PGN-plus-E is the electric counterpart to the pneumatic universal gripper. It is also equipped with improved multi-tooth guidance and permanent lubrication, its gripping force is variable in four steps.

The new PGN-plus-P and the new PGN-plus-E are the result of 30 years SCHUNK competence. We are proud of this.

**Benefit from the advantages:**

up to **50%**  
longer gripper fingers

up to **120%**  
higher finger load





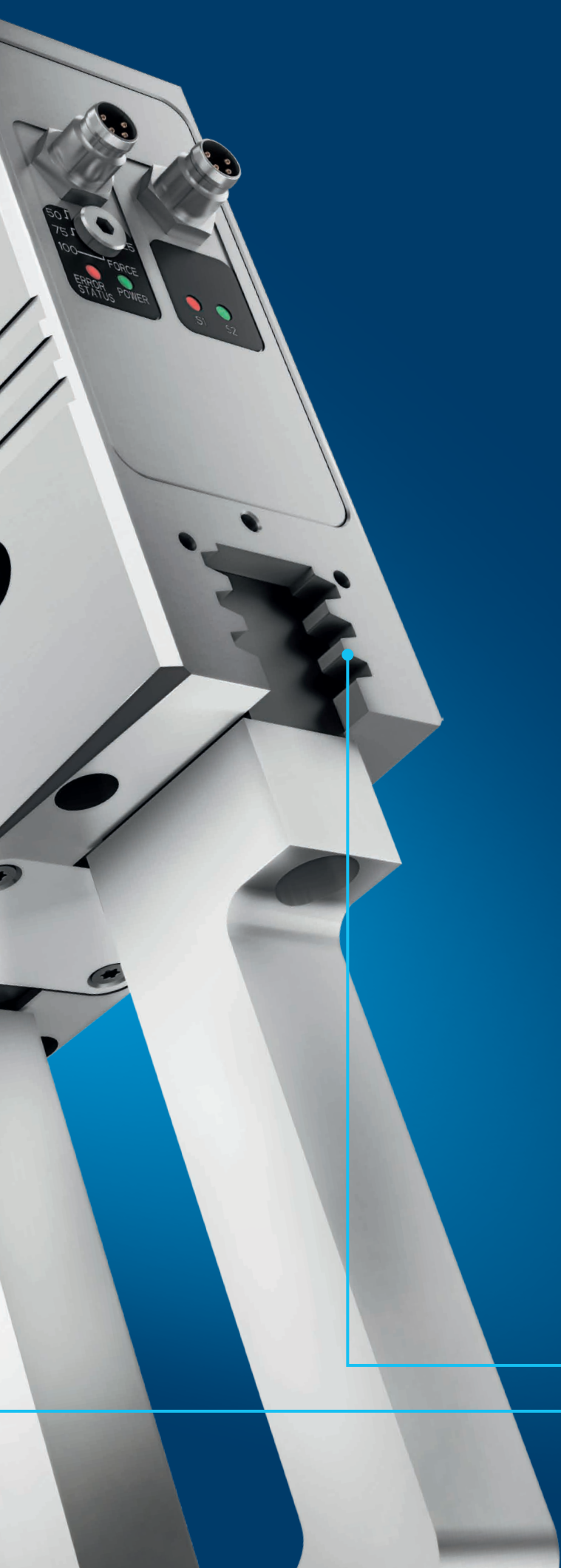

## The new SCHUNK Grippers PGN-plus-P and PGN-plus-E. Now NEW with Permanent Lubrication in the Multi-tooth Guidance!

The new SCHUNK PGN-plus-P universal gripper with unique permanent lubrication combines innovative technology with SCHUNK gripping technology that has proven its effectiveness 100,000 times over. It is based on the SCHUNK PGN-plus with multi-tooth guidance, which is the market-leading, premium product. With technological perfection and unique precision because of its multi-tooth guidance, the SCHUNK PGN-plus sets the benchmark for pneumatic universal grippers.

Never before has a gripper been so precise as with the superior multi-tooth guidance from SCHUNK. Now, SCHUNK has provided the multi-tooth guidance contour with continuous grease pockets. These provide a continuous supply of grease and ensure that an even lubricant film is created rapidly, even with short strokes.

The effect: Permanent lubrication increases the already long life span of the SCHUNK perennial and makes it practically maintenance-free.

Your benefits by using the new SCHUNK universal grippers PGN-plus-P and PGN-plus-E

- Rapid and even lubricant distribution even with short strokes
- Reduced total cost of ownership (TCO)
- Permanently higher performance
- More compact, efficient systems
- Continuously reliable and robust



**Patented Precision!**  
*Patentierte Präzision!*

Multi-tooth guidance  
*Vielzahnführung*

# The patented SCHUNK Multi-tooth Guidance. Proven Technology. Now even better!

The new SCHUNK grippers PGN-plus-P and PGN-plus-E are the result of 30 years SCHUNK competence. They are the result of a sophisticated innovation strategy to continuously expand the proven basic components with state-of-the-art features. In 2000, SCHUNK recognized that the T-slot guide used for many conventional grippers was a weak point. This was when the SCHUNK multi-tooth guidance was born, which makes the SCHUNK universal gripper PGN-plus the world's best gripper.

## T-slot Guidance. Conventional Technology.

The generated forces and torques must be shouldered by **two guideways**.

- Considerable load peaks
- Premature wear
- Loss in precision



↑ Finger load



↑ Longer gripper fingers



## SCHUNK Multi-tooth guidance. Patented Technology.

Forces and torques are distributed to the **guiding areas of several prism guides arranged in parallel**.

- Guides have a higher bearing capacity
- Considerably better stability



↑ +100%

↑ +30%

**Patented Precision!**  
*Patentierte Präzision!*

**P** Multi-tooth guidance  
*Vielzahnführung*

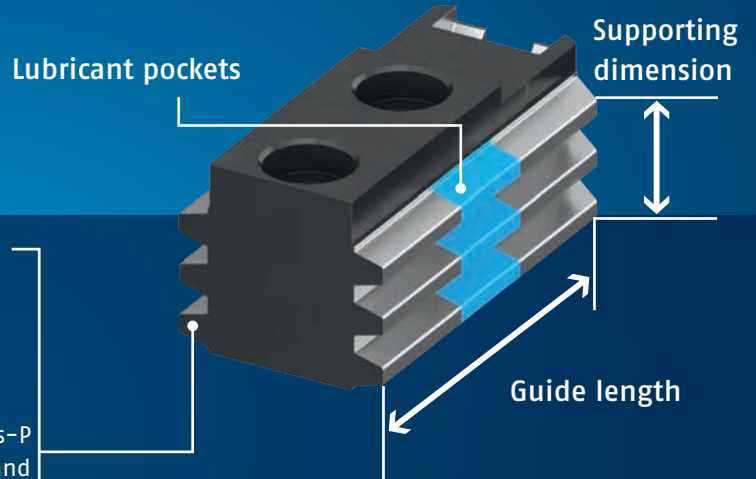

## The new SCHUNK Multi-tooth Guidance of the new Grippers PGN-plus-P and PGN-plus-E.

The guiding surfaces of the new SCHUNK grippers PGN-plus-P and PGN-plus-E were **equipped with lubricant pockets**, and the **supporting dimension between the six load-bearing shoulders** was considerably increased.

- Higher maximum load
- Longer gripper fingers

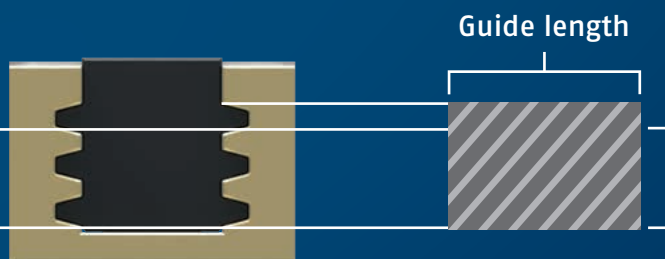

up to **40%** higher supporting dimension due to enlarged supporting surfaces

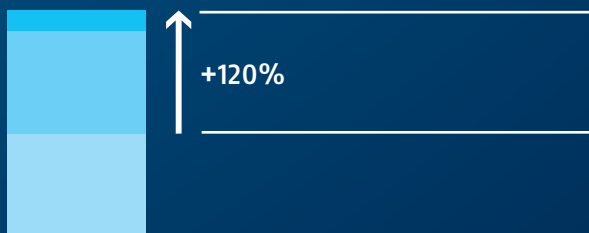

up to **120%** higher finger load possible

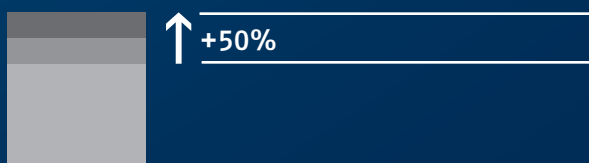

up to **50%** longer gripper fingers can be used

## The new SCHUNK Gripper PGN-plus-P.

The world-proven Gripper on the market –  
Now NEW with Permanent Lubrication in the Multi-tooth Guidance.  
Lifelong maintenance-free.\* Guaranteed!

With the new PGN-plus-P, SCHUNK is once again raising the bar for pneumatically powered universal grippers. Due to consistent optimization of the multi-tooth and force, it sets the new benchmark for the market. At the same time, the new PGN-plus-P benefits from the unique SCHUNK accessory program for the nearly complete spectrum of feasible automation applications.

\* Under normal, clean operating conditions.





## Up to 50% longer gripper fingers – due to higher maximum moments

The improved multi-tooth guidance allows the use of even longer gripper fingers due to higher maximum moments while retaining the same gripper size, without overloading the guidances.

Gripping with optimized interfering contours for spatially constrained handling tasks has been made even easier as a result.

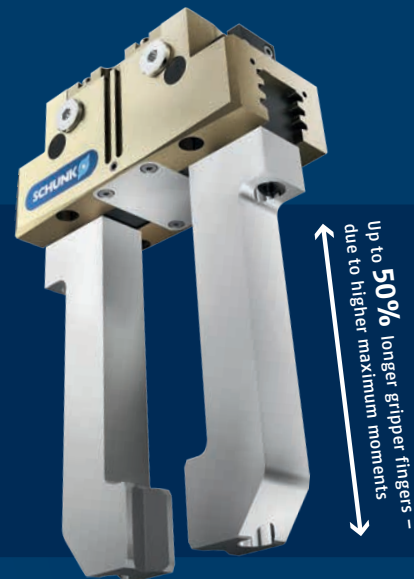

## Higher force

With the enlarged surface of the drive piston in the existing and simultaneously compact installation space, the gripping force of the new PGN-plus-P is increased. Higher workpiece weights can be handled in relation to the gripper size.

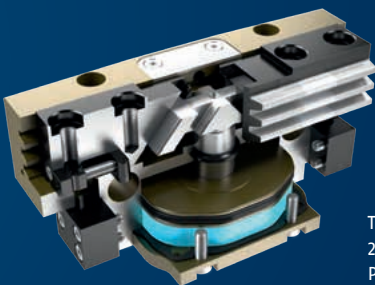

The new pneumatic 2-finger parallel gripper PGN-plus-P



## Longest life span due to lubrication pockets in the durable multi-tooth guidance

Lubricant pocket through-holes ensure a permanent supply of lubricant. At the same time, they assure a quick and even formation of a lubricant film, also in the case of short strokes.

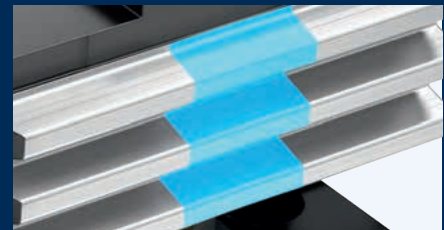

## Maximum process reliability

The new multi-tooth guidance allows a larger wedge hook surface and therefore lower surface pressure for low-wear transmission of forces to the base jaw for a reliable process.

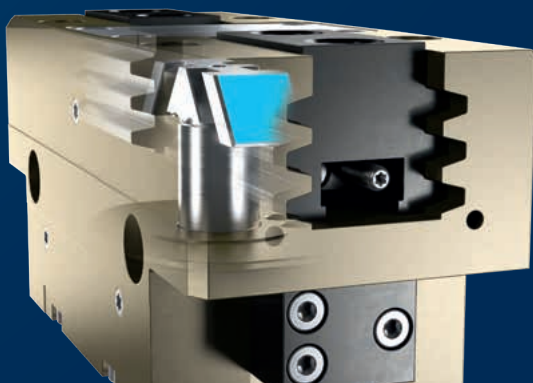

## Diverse accessories

There is a wide range of high-quality accessory components available for the new grippers SCHUNK PGN-plus-P. Of course, this spectrum includes the right sensors as well as efficient micro valve technology for shorter cycle times and lower energy consumption.



### Perfectly coordinated accessories

e.g. ABV micro valves  
Shorter cycle times with reduced pneumatic energy consumption.



### Sensor systems

e.g. sensor MMS  
Reliable and economic for position monitoring with LED display for control of switching position.

# The new SCHUNK Gripper PGN-plus-E.

The first easy electric gripper with proven multi-tooth guidance.  
With permanent lubrication in the multi-tooth guidance, digital control  
and 24 V drive.

The new electric SCHUNK gripper PGN-Plus-E applies the proven high-performance features of the new pneumatic gripper PGN-plus-P in the area of mechatronic handling. The first simple electric gripper with multi-tooth guidance, digital control, and 24 V drive makes the switch from pneumatic to electric components especially easy. Its digital I/O control via binary signals simplifies commissioning and enables quick integration into existing systems.





### Up to 50% longer gripper fingers

The improved multi-tooth guidance allows the use of even longer gripper fingers due to higher maximum moments while retaining the same gripper size, without overloading the guidances.



### Easy gripping force adjustment

The gripping force of the new SCHUNK PGN-plus-E can be adjusted quickly, safely, and manually in four stages.



### Longest life span due to lubrication pockets in the durable multi-tooth guidance

Lubricant pocket through-holes ensure a permanent supply of lubricant. At the same time, they ensure a quick and even formation of a lubricant film, also in the case of short strokes.

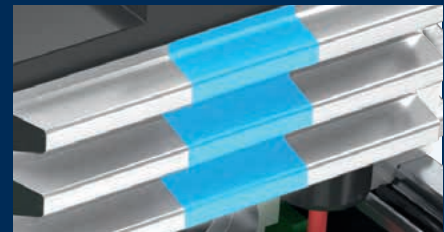

### Maximum process safety

Multi-tooth guidance allows a larger wedge hook surface and therefore lower surface pressure for low-wear transmission of forces to the base jaw for a reliable process.

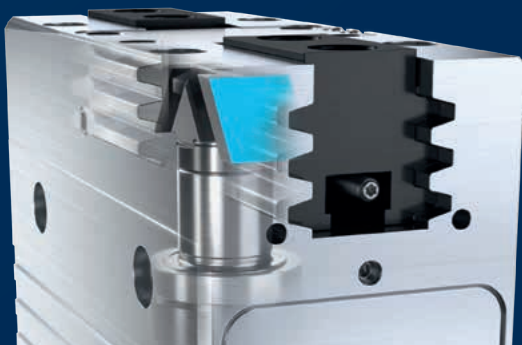

### Integrated sensor system

The control and power electronics are fully integrated, which ensures that no additional space in the switch cabinet is required. The 24 V gripper is actuated via digital I/O. M8 plug connectors query up to 2 gripper positions.



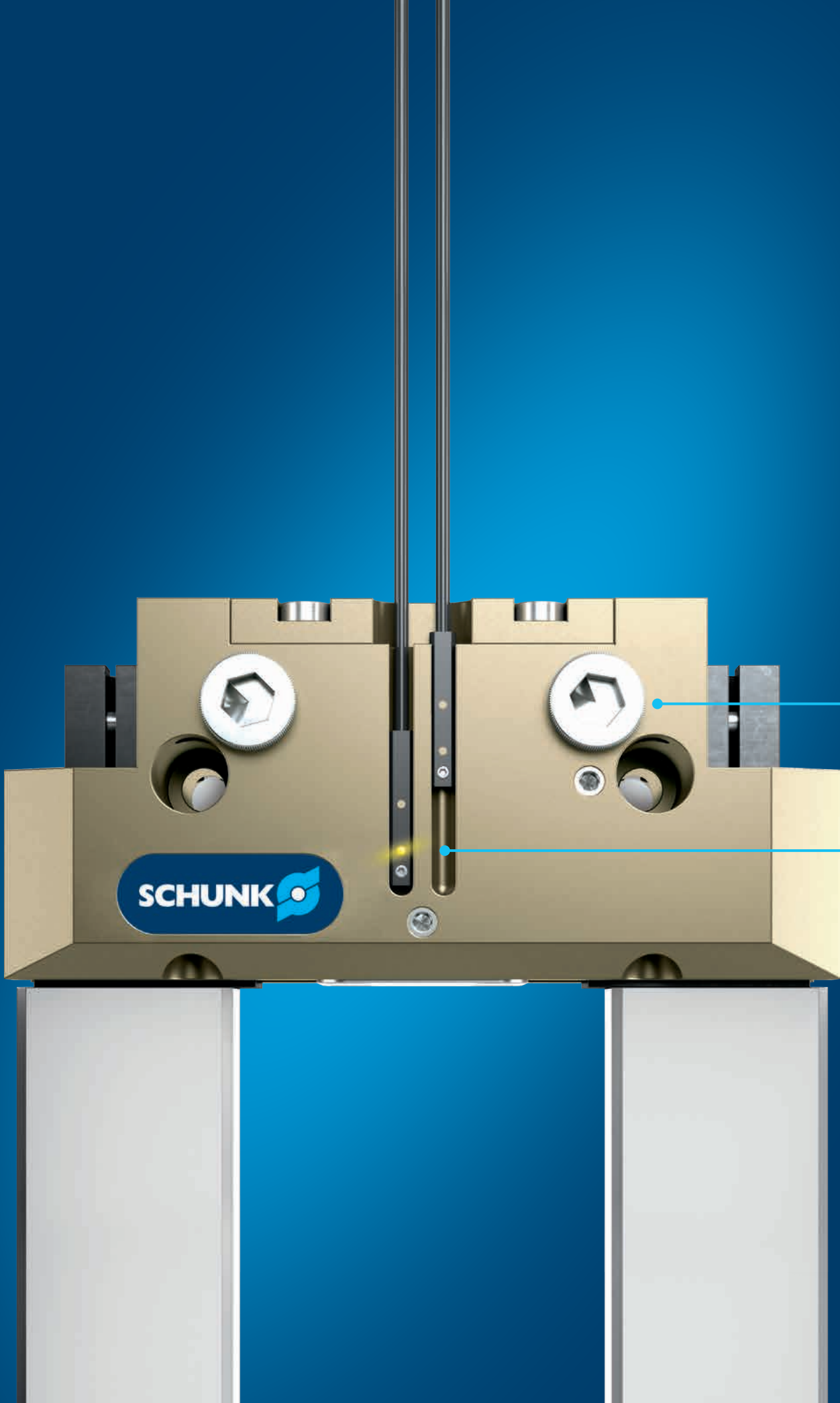



# Our Answer to Flexibility: Diversity of Accessories.

The new SCHUNK gripper PGN-plus-P stands for diversity. You benefit from unprecedented flexibility. Choose from a large range of high-quality accessory components provided by SCHUNK for its grippers with multi-tooth guidance. They are the perfect way to equip your new PGN-plus-P for your individual application. Combine different options with no compromises for the reliable special version, if special environmental conditions should require it.

Of course, our performance spectrum also includes the matching sensor systems, as well as efficient micro valve technology for shorter cycle times and low power consumption.



## Valves

### Micro valve MV

The two SCHUNK micro valves with a cylindrical design can be mounted directly on the gripper. This reduces cycle times, wiring and compressed air costs.



## Sensor system

### MMS 22-PI magnetic switch

The SCHUNK MMS 22-PI sensors allow programming of up to two switching points, depending on the version.



## Variants

### Multi-tooth is part of our philosophy

Discover the diversity of SCHUNK grippers with multi-tooth guidance. Whether 3- or 4-finger centric, in a sealed version or with a center hole. Take advantage of the reliable performance for your special handling task.

# Our Diversity. Your Individuality.

The new SCHUNK PGN-plus-P gripper line with multi-tooth guidance, and a standardized screw pattern offers diverse versions and a superior line of accessories to give you everything you need for flexible use in your special automation application. For every type of application and handling requirement – even for extreme conditions.



Variants		The new 2-finger parallel gripper PGN-plus-P
<b>Gripping force maintenance version AS/IS</b>		●
<b>Dust-protected version SD</b>		●
<b>Corrosion-protected version K</b>		●
<b>High-temperature version V</b>		●
<b>Power booster version KVZ</b>		●
<b>Precision version P</b>		●
<b>Explosion-proof version EX</b>		●
<b>Compatible accessories*</b>		
<b>Protective cover HUE</b> Permanent protection of the gripper against liquids and dust.		●
<b>Jaw quick-change system BSWS</b> Minimizes setup times due to quick changing of the gripper fingers.		●
<b>Top jaw blank ABR/SBR</b> Blanks made of aluminum or steel for application-specific finish machining.		●
<b>Laser-formed gripper fingers</b> Customized gripper fingers made of polyamide by means of laser forming; available within a few days.		●
<b>Micro valves ABV</b> Shorter cycle times with reduced pneumatic power consumption.		●
<b>Pressure maintenance valve SDV-P</b> Guarantees maintenance of gripping force in case of a power failure.		●
<b>Sensor systems*/Position monitoring</b>		
<b>Magnetic switch MMS</b> Features one switching point. No interfering contour.		●
<b>Inductive proximity switch IN</b> For monitoring the current condition of automation components.		●
<b>Sensor systems*/Multi position monitoring</b>		
<b>Flexible position sensor FPS</b> For monitoring of up to 5 teachable switching points with digital output.		●
<b>MMS 22-PI magnetic switch</b> With adjustable hysteresis. Optionally with two programmable switching points.		●
<b>Magnetic sensor MMS-A</b> Smallest teachable analog sensor for the C-slot. No interfering contour.		●
<b>Analog position sensor APS</b> System consisting of sensor and electronics for precise monitoring of any number of gripper jaw positions.		●
<b>Wireless sensor system*</b>		
<b>Wireless monitoring system RSS</b> Wireless sensor system for signal and condition monitoring of sensors and processes.		●

● Available as standard    ▲ On request: Technical hotline for gripper systems +49-7133-103-2696    \* more accessories and sensors at schunk.com

# SCHUNK Grippers: All with Multi-tooth – all for your Application!



Handling of round workpieces.	Use in water and contaminated environments.		Center bore for workpiece feeding, sensors or optical detection.		Handling of cylindrical workpieces during magazing and palletizing
3-finger centric gripper PZN-plus	2-finger parallel gripper Sealed version DPG-plus	3-finger centric gripper Sealed version DPZ-plus	2-finger parallel gripper with center bore PGB-plus	3-finger centric gripper with center bore PZB-plus	4-finger centric gripper PZV-plus
•	•	•	•	•	▲
•	•	•	▲	▲	▲
•	•	•	▲	▲	▲
•	•	•	•	•	•
•	•	•	▲	▲	▲
•	•	•	▲	▲	▲
•	•	•	▲	▲	▲
•	•	•	•	•	•
•	•	•	•	•	•
•	•	•	•	•	•
•	•	•	•	•	•
•	•	•	•	•	•
•	•	•	•	•	•
•	•	•	•	•	•
•	•	•	•	•	•

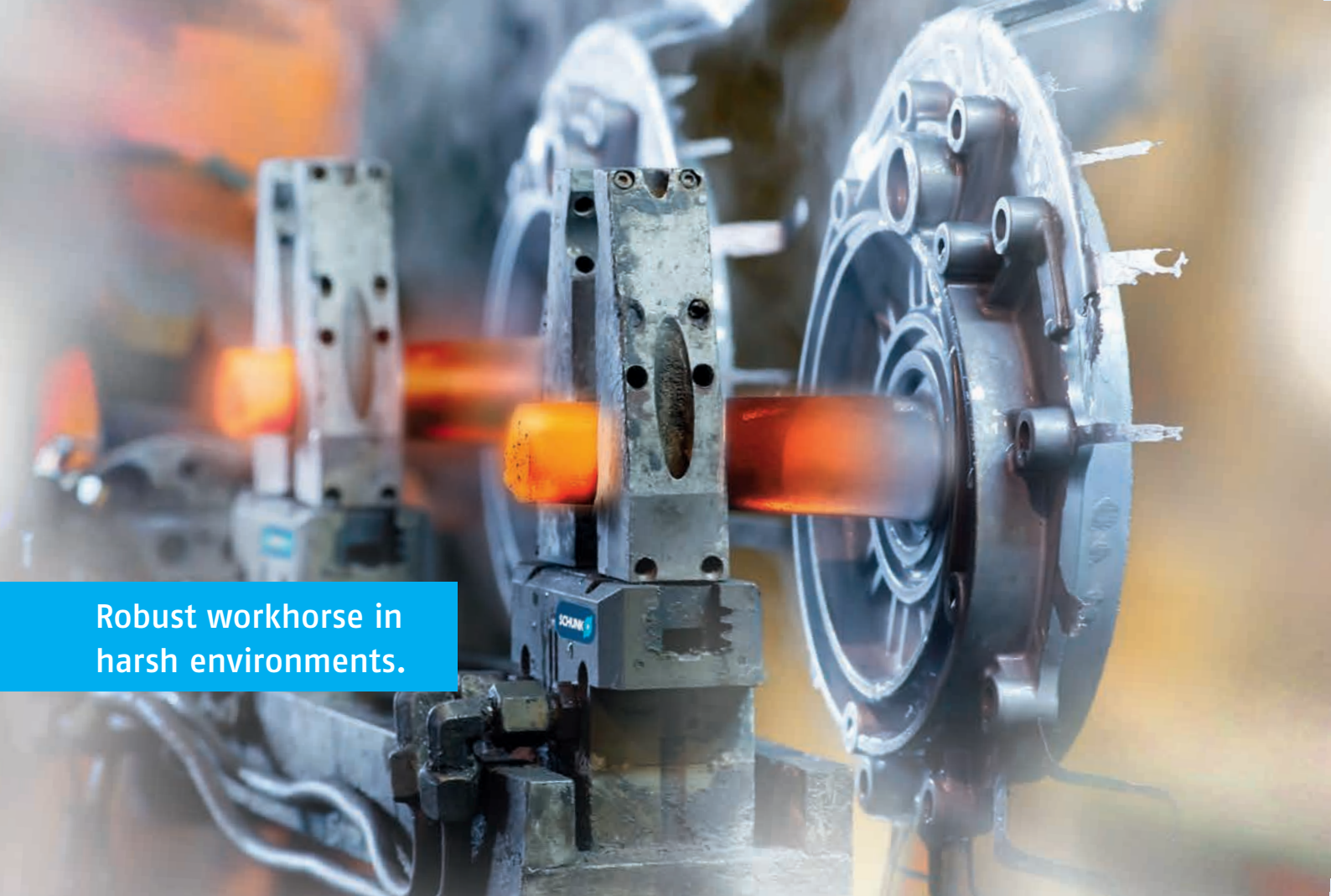

Robust workhorse in harsh environments.

## You have your Requirement. We have the new PGN-plus-P!

**The new PGN-plus-P stands for efficiency and precision in handling applications.** More than 500,000 solutions implemented in diverse industries speak for themselves. The new PGN-plus-P is the perfect gripper for every type of application with special environmental conditions such as temperature, contamination or aggressive media, as well as in cleanroom conditions or explosive environments. The new PGN-plus-P – you decide where to use it.

### Dust-protected version

For use in dusty environments. Fully dust-proof versions with increased degree of protection against penetrating materials, for absolute reliability.



### Cleanroom

The new PGN-plus-P in the standard version is certified according to EN ISO 14644 cleanroom class ISO 5, with protective cover HUE also for standard use in cleanroom class ISO 2.



 **Cleanroom®**  
Suitable  
Materials



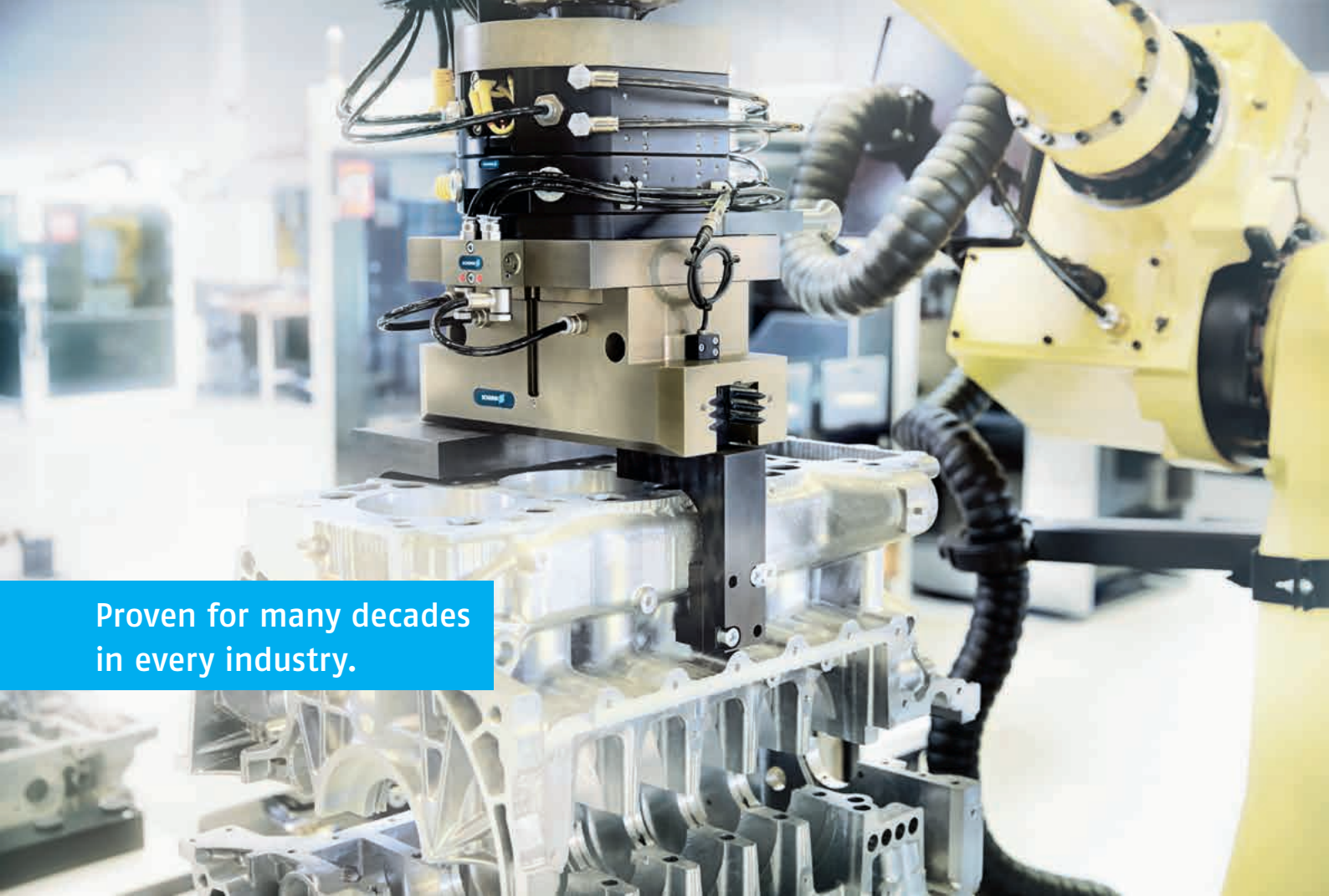

Proven for many decades  
in every industry.



Automotive industry



Machining industry



Electrical industry



Drive technology



Medical technology

### Explosion-proof version EX

All premium products from SCHUNK are also delivered with an ATEX certificate as standard.



### Customized protective covers

For use in high-temperature areas, such as for welding.



# The new PGN-plus-P – ready for every Application. For every Task. For every Industry.



## Removal of pistons

### Casting industry

The new PGN-plus-P in combination with an OPR collision sensor. Imaging software is used to determine possible gripping points for removal of components.



## Loading and unloading of a machining center

### Machining industry

Robots with the SCHUNK SWS quick-change system load SCHUNK TANDEM-plus clamping force blocks outside of the machining center and completely exchanges them with one gripping unit, consisting of two new grippers PGN-plus-P into the vertical machining center.

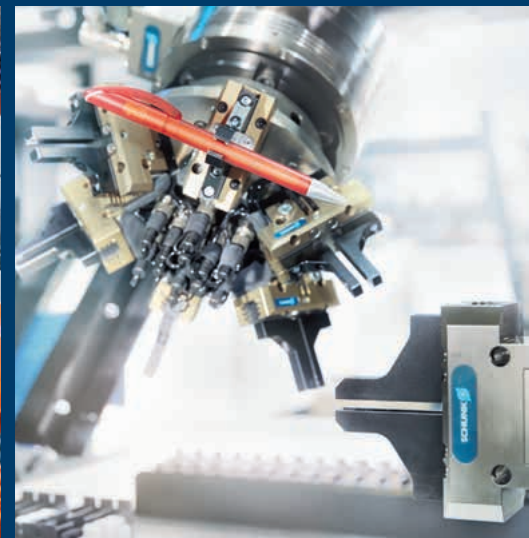

## Collection & placing of small components

### Assembly automation

Universal SCHUNK stacking gripper RVK equipped with six new parallel grippers PGN-plus-P. Components are successively gripped, collected and conveyed to the assembly or storage area and then set down individually.

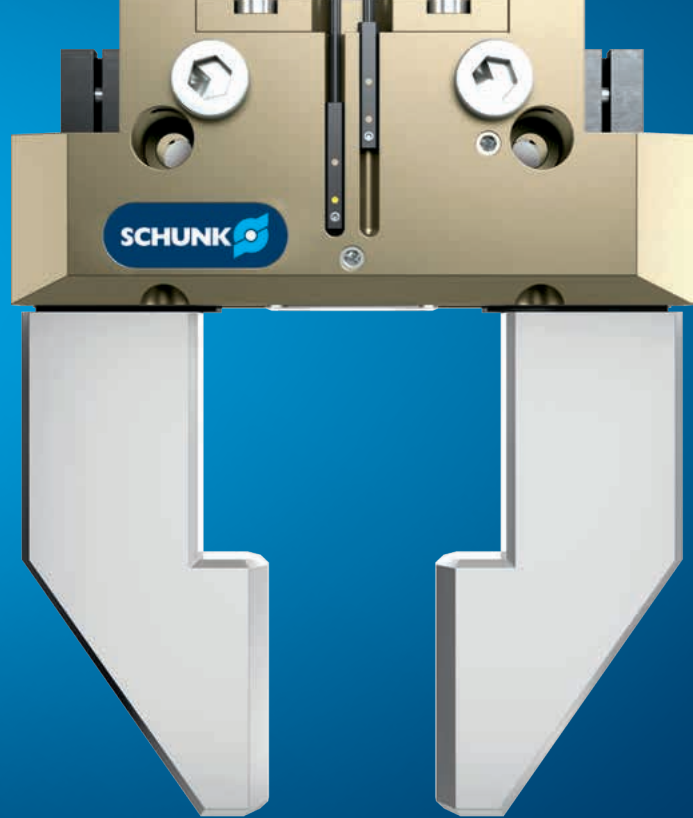

### Palletizing of pre-machined parts

#### Assembly automation

Pre-machined parts are removed from the machining process with a new PGN-plus-P and stored on a pallet for further processing.



### Loading and unloading of a machining center

#### Machining industry

I.D. clamping of a pre-machined part with a hydraulic power chuck ROTA NCK-S plus and claw jaws. Loading and unloading is performed automatically by a new PGN-plus-P.



### Handling of ground parts

#### Machining industry

Six-way robot uses a new PGN-plus-P to remove a machined part from the chuck. The finished parts are placed on a pallet; rough parts are gripped from a pallet.

# Standardization for maximum Flexibility. The new PGN-plus-P and End-of-Arm Competence from SCHUNK

More capabilities, more functionality, higher process reliability and maximum modularity. SCHUNK robot accessories include a comprehensive portfolio of modules for mechanical, sensor and power connections between the effector and the robot. A broad range of quick-change systems, rotary feed-throughs, anti-collision and overload devices, force sensors, compensation units and insertion units ensure optimal interplay between the robot arm and end-of-arm effectors, such as the SCHUNK new gripper PGN-plus-P.





# High-speed for Handling and Assembly.

## The new PGN-plus-P and Axis System Handling Solutions from SCHUNK

When precision is required for positioning, loading, and unloading, assembly or transport, the interplay of the new PGN-plus-P and pneumatic and electric linear modules from SCHUNK provide the perfect solution.

With the performance range of linear modules in combination with rotary modules, rotary units, gripping modules, quick-change systems, rotary transfer units and sensors, SCHUNK opens up new perspectives for optimally priced and value-added automation solutions.

### Gripping

The new SCHUNK gripper PGN-plus-P  
2-finger universal gripper with multi-tooth guidance



Inserting and compensating  
SCHUNK Tolerance Compensation Unit TCU



### Moving

SCHUNK linear modules  
X-axis (horizontal)  
Beta toothed belt axis  
Z-axis (vertical)  
Beta spindle axis

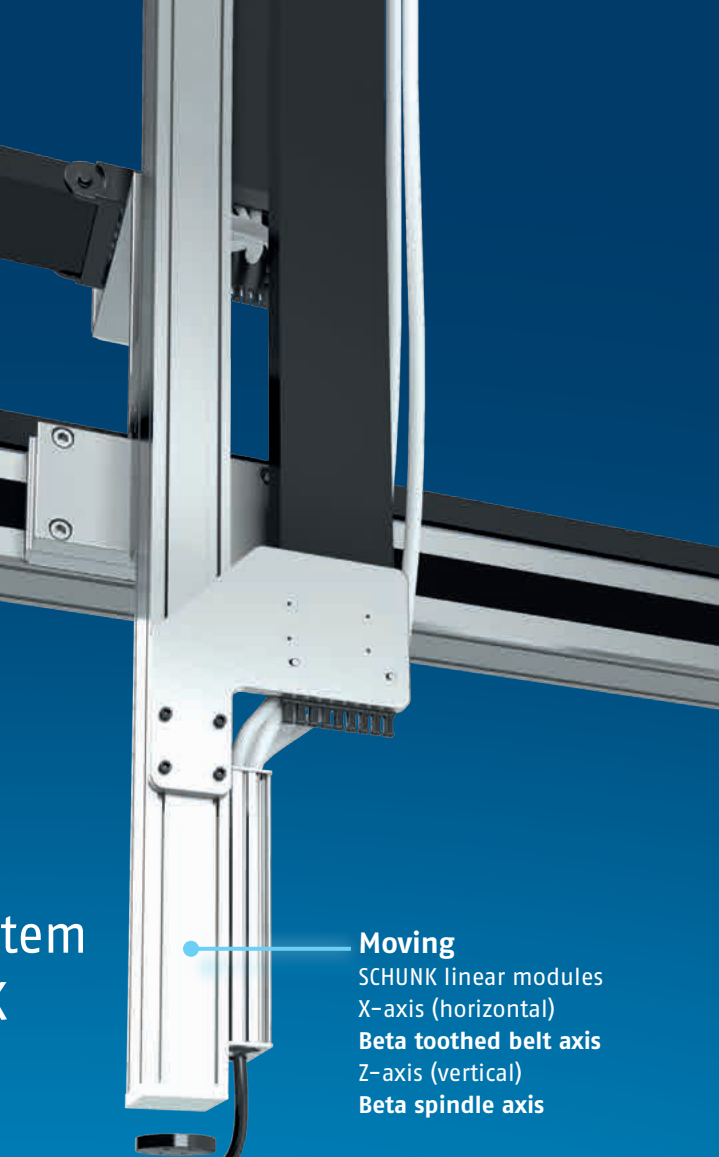

### Connecting

SCHUNK adapter plate

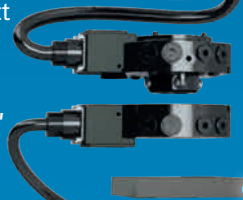

### Turning

SCHUNK rotary unit  
SRH-plus



### Connecting

SCHUNK adapter plate



### Gripping

The new SCHUNK gripper PGN-plus-P  
2-finger universal gripper with multi-tooth guidance

# With more than 4,000 standard components SCHUNK offers the most comprehensive product portfolio of gripper systems worldwide.

The new SCHUNK gripper PGN-plus-P exemplifies our philosophy: Diversity of variants in the standard version plus diverse possible options.

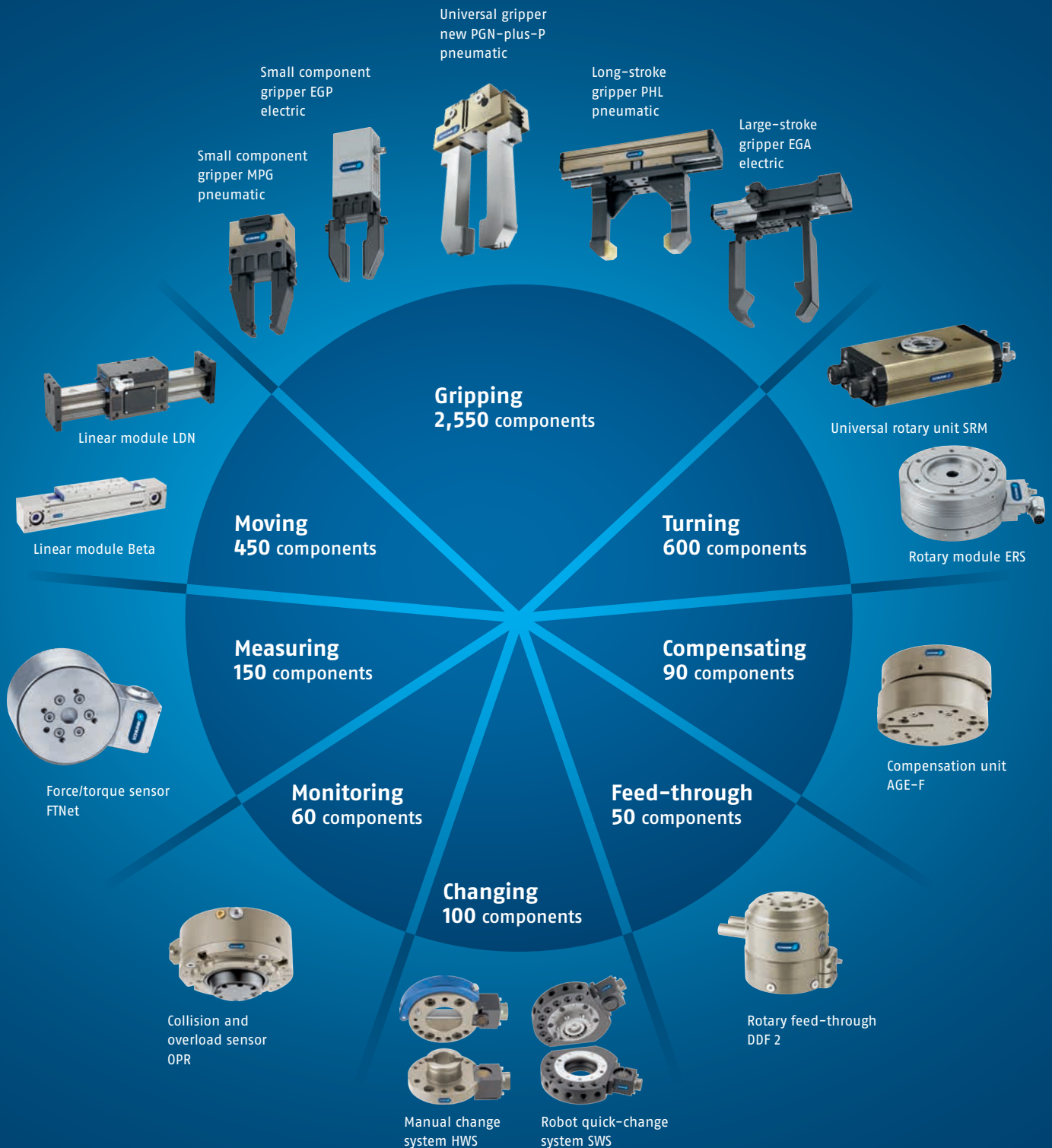

# All inclusive! SCHUNK customized Gripping Systems. Take Advantage of our Experience.

More than 12,000 implemented solutions speak for themselves.

Consistent and comprehensive project management is an important part of the SCHUNK philosophy. Our approach is systematic and individually adapted to your project; each step is traceable and documented.

The analysis of complex processes and the comprehensive analysis of components and products of our customers leads SCHUNK to develop effective and customized gripping systems.

The visualization of automated processes requires maximum precision – we use state-of-the-art technology for 2D and 3D visualizations and 3D simulations. Our components and configurations contain decisive performance potential for the cost effectiveness of your process chain. We exhaust this potential. Entirely for your benefit.

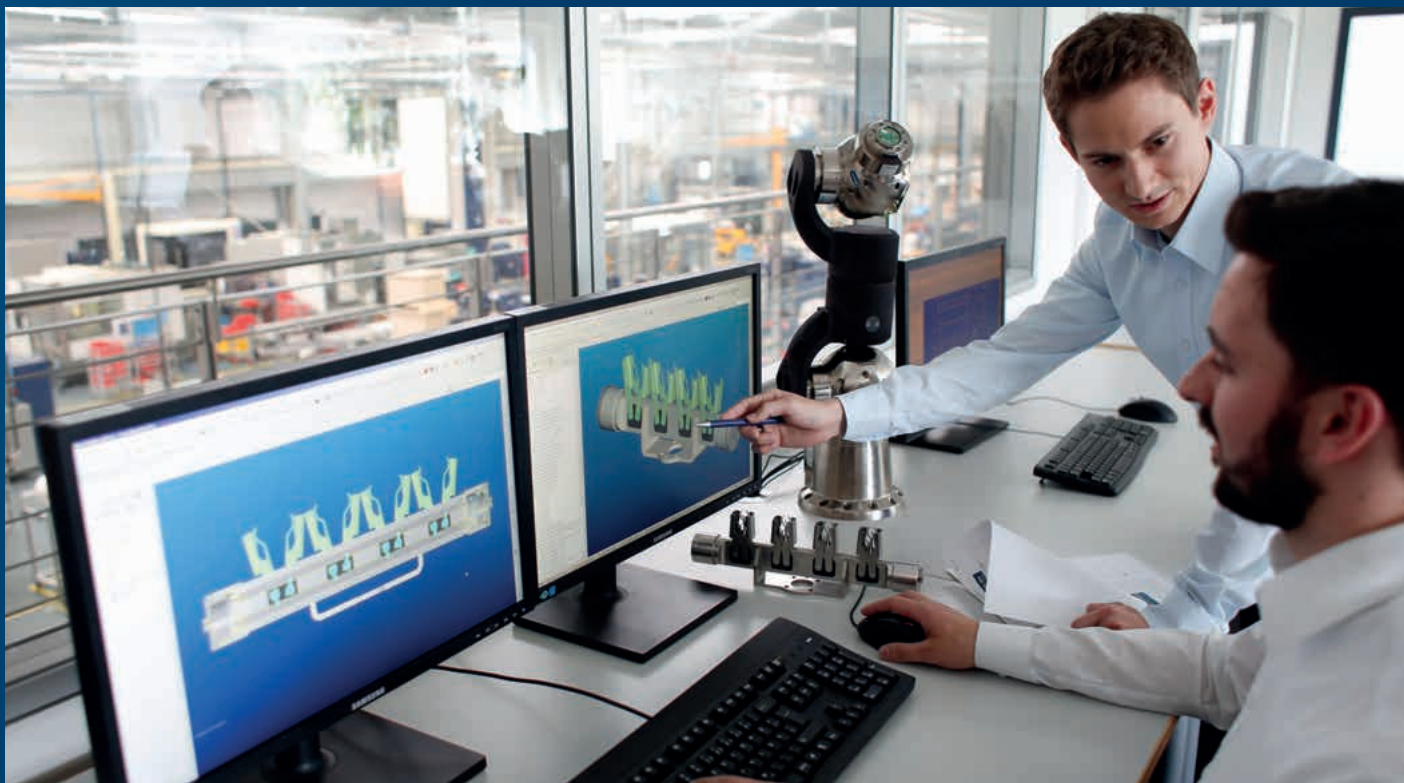

# SCHUNK Gripping Systems.

## Customized Components and Gripping Systems

More than 30 years of gripping competence form the basis for the world's most extensive standardized gripping technology portfolio with more than 4,000 components and for an average of 2,000 standard and customized gripping systems per year.

### Components

#### Standard components



SCHUNK grippers



Rotary modules



Linear modules



Robot accessories



Pick & place units



Gripping hands



Lightweight arms

#### Customized components

From standard components adapted to meet individual requirements to exclusive new customized developments.

Examples:



Wafer grippers of laser-formed material with SCHUNK gripper LGP



Compact clamp for sheet metalworking, pneumatically operated



Packaging grippers High-speed grippers in accordance with legal, hygienic and production specifications

### Gripping systems

#### Standard gripping systems



Modular assembly automation



Linear and 3D gantries



Solution from several SCHUNK standard components for robots and gantries

#### Customized gripping systems

Solution from several SCHUNK components, including at least one custom development.

Examples:

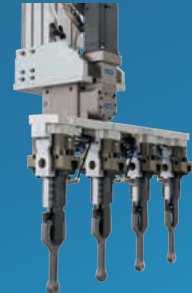

Connecting rod handling



Aluminum foil handling



Modular and mobile gripping systems

# From standard Components to customized Gripping Systems

## A competent contact person for your solution from a single source

For smooth communication a personal contact person is available to you throughout the entire project. As the interface between you and the people involved in the project, this contact ensures the effective exchange of information.

From planning through continued support after completion of the project – SCHUNK guarantees a cooperative and efficient project flow.

## Your advantage

- More than **30 years of experience** in gripping technology
- More than **12,000 gripping systems** implemented for diverse industries
- **Modular system** with perfectly compatible standard components
- **An absolutely exact fit** due to standard interfaces
- **Shorter project cycle times** due to standardized systems
- Reliable implementation and **planning security** without additional project costs
- **Functional assemblies** mounted or **ready for use on request**
- **Time savings** due to a perfect solution from a single source

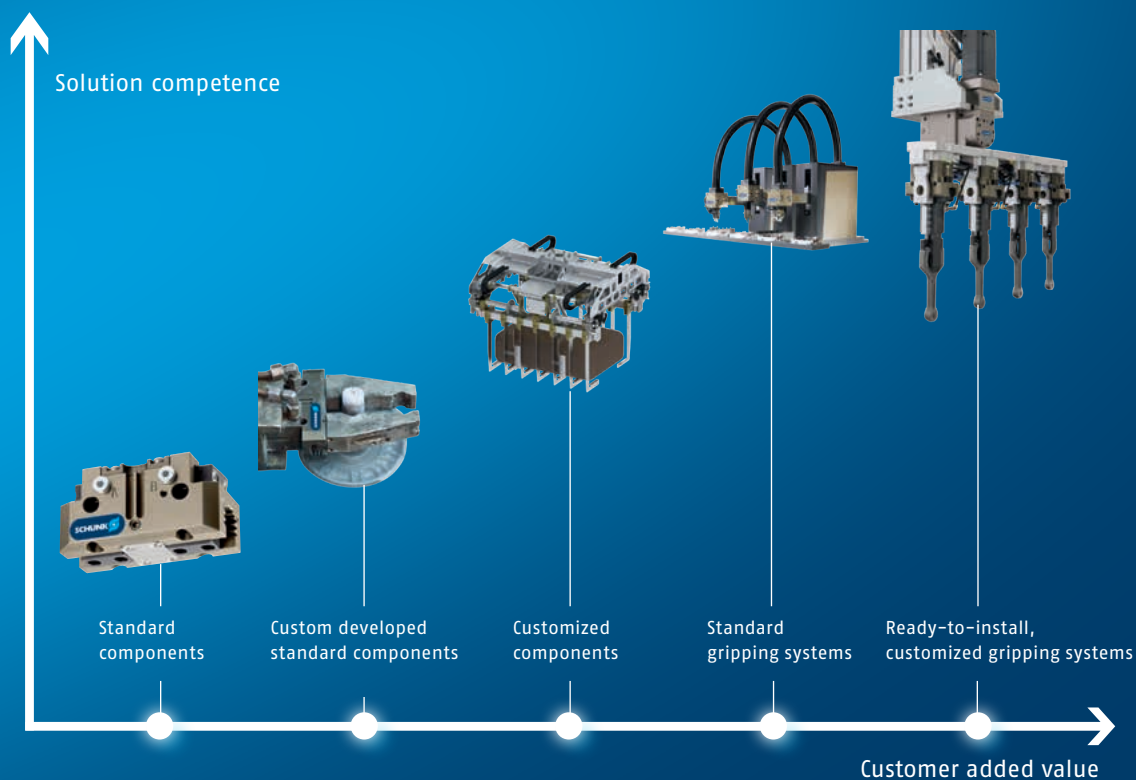

# SCHUNK Service



Competent and skilled personnel ensure optimal availability of your SCHUNK products, and make sure that their value will be maintained.

## Your advantage:

- Fast supply of original spare parts
- Reduction of down-times
- The complete spectrum of components from one source
- Quality and availability that can only be guaranteed by the original manufacturer
- 12-month warranty



## Initial operation

- Professional assembly
- Fast and trouble-free



## Inspection

- Inspection is carried out by skilled service engineers
- Avoiding unplanned failures of workholding and toolholding equipment



## Maintenance

- Regular maintenance carried out by skilled service engineers
- Increasing and ensuring the availability of your workholding and toolholding equipment



## Repairs

- Short down-times due to fast intervention of the SCHUNK service engineers
- Spare parts and accessories

## Training

- Fast and practical training
- Efficient use of your SCHUNK products by training of the operating personnel
- The basis for proper machining of workpieces
- Ensures longevity of your SCHUNK products

## Individual service – for better results

- Hotline to our inside technical consultants weekdays from 7 a.m. to 6 p.m.
- Project-oriented and on-site technical advice at your location
- Training on innovations and SCHUNK products – across the world in our local subsidiaries

## Online service – for a fast overview

All information in digital form, clearly structured and up-to-date on our website at [www.schunk.com](http://www.schunk.com)

- List of contact persons
- Online product search based on product descriptions
- Product news and trends
- Data sheets
- Order forms for easy and convenient ordering
- Free download area for pages from our product catalogs and technical data, for software and calculation programs for your gripping and rotary modules
- Free 2D/3D CAD design models, provided in a wide range of different CAD formats – for easy integration into your design!



[schunk.com/service](http://schunk.com/service)

# Plants

Germany



## Headquarter Lauffen/Neckar

SCHUNK GmbH & Co. KG | Spann- und Greiftechnik  
Bahnhofstr. 106 - 134 | 74348 Lauffen/Neckar  
Tel. +49-7133-103-0  
Fax +49-7133-103-2399  
info@de.schunk.com | schunk.com



## Brackenheim-Hausen

SCHUNK GmbH & Co. KG | Spann- und Greiftechnik  
Wilhelm-Maybach-Str. 3 | 74336 Brackenheim-Hausen  
Technical Sales +49-7133-103-2503  
Technical Support +49-7133-103-2696  
Fax +49-7133-103-2189  
automation@de.schunk.com | schunk.com



## Mengen

H.-D. SCHUNK GmbH & Co. Spanntechnik KG  
Lothringer Str. 23 | 88512 Mengen  
Tel. +49-7572-7614-0  
Fax +49-7572-7614-1039  
futter@de.schunk.com | schunk.com



## St. Georgen

SCHUNK Electronic Solutions GmbH  
Am Tannwald 17 | 78112 St. Georgen  
Tel. +49-7725-9166-0  
Fax +49-7725-9166-5055  
electronic-solutions@de.schunk.com | schunk.com



## Huglfing

SCHUNK Montageautomation GmbH  
Auwiese 16 | 82386 Huglfing  
Member of SCHUNK Lauffen  
Tel. +49-8802-9070-30  
Fax +49-8802-9070-340  
info@de.schunk.com | schunk.com



## Werk Winkler Lauffen

Winkler Präzisionswerkzeuge GmbH  
Im Brühl 64 | 74348 Lauffen/Neckar  
Member of SCHUNK Lauffen  
Tel. +49-7133-97440-0  
Fax +49-7133-97440-99  
post@winkler-gmbh.de | schunk.com

## International



## Morrisville/North Carolina, USA

SCHUNK Intec Inc.  
211 Kitty Hawk Drive | Morrisville, NC 27560  
Tel. +1-919-572-2705  
info@us.schunk.com  
us.schunk.com



## Aadorf, Switzerland

GRESSSEL AG  
Schützenstr. 25 | 8355 Aadorf  
Tel. +41-52-368-16-16  
Fax +41-52-368-16-17



## Caravaggio, Italy

S.P.D. S.p.A.  
Via Galileo Galilei 2/4 | 24043 Caravaggio (BG)  
Tel. +39-0363-350360  
Fax +39-0363-52578





[schunk.com/catalogorder](http://schunk.com/catalogorder)

## The SCHUNK Gripper Catalog

The world's most comprehensive gripper portfolio of more than 1,800 pages. Order now!

# No. 1

for safe, precise  
gripping and holding.



*J. Lehmann*

Jens Lehmann, German goalkeeper legend,  
SCHUNK brand ambassador since 2012  
for safe, precise gripping and holding.  
[schunk.com/lehmann](http://schunk.com/lehmann)

**852** minutes without a  
goal against him in the  
Champions League

**681** minutes without a goal  
against him in the national team

**2** intercepted penalties  
in the 2006 World Cup

**1** headed goal as a goalie

**0** defeats English Soccer Champion

and

More than **2,000,000**  
sold precision toolholders

About **1,000,000**  
delivered SCHUNK grippers

More than **100,000**  
lathe chucks and stationary  
workholding systems are in use  
worldwide

More than **16,000,000**  
sold standard chuck jaws

More than **75,000**  
implemented hydraulic expansion  
customer-specific solutions

SCHUNK GmbH & Co. KG  
Spann- und Greiftechnik

Bahnhofstr. 106 - 134  
D-74348 Lauffen/Neckar  
Tel. +49-7133-103-2503  
Fax +49-7133-103-2189  
[cmg@de.schunk.com](mailto:cmg@de.schunk.com)

 [schunk.com](http://schunk.com)

 [youtube.com/schunkhq](https://youtube.com/schunkhq)

 [twitter.com/schunk\\_hq](https://twitter.com/schunk_hq)

 [facebook.com/schunk.hq](https://facebook.com/schunk.hq)

